



Pregis

EASYPACK®
QUANTUM SERIES
PAPER PACKAGING BY PREGIS

User Manual v1.2



Quantum Series User Guide

Table of Contents

Introduction.....	2
General Safety	3
Understanding the Controls.....	4
Operation.....	6
Maintenance	13
Trouble Shooting.....	14
XT Specifications.....	15
XTW Specifications	16

Introduction

The Pregis Quantum Series includes the Quantum XT and Quantum XTW systems. Each system dispenses recycled paper void fill both on demand and at predetermined lengths, as needed. These user-friendly systems save storage space and reduce packaging material waste while providing unmatched safety, reliability and enhanced ergonomic features that increase operator productivity.

System Snapshot

Quantum XT: Low-medium volume applications & centralized workstations, converts paper rolls
Quantum XTW: High volume applications & decentralized workstations; converts fanfold paper

Quantum XT Paper Void Fill Material:

Item #	Formulation	Roll Widths	Roll Length
475635	30# Renew 100% recycled content	12-in	2,200-ft
480682	45# Renew 100% recycled content	12-in	1,700-ft
480682	30# recycled content Kraft paper	12-in	2,400-ft
480682	45# recycled content Kraft paper	12-in	1,700-ft

Quantum XTW Paper Void Fill Material:

Item #	Formulation	Bundle Width	Bundle Length
4068969	30# Recycled Kraft fanfold	29.5-in	1,690-ft



General Safety

Operator safety and the safety of others in the work area depend on the operator using good judgment and reasonable care while utilizing the machine. This user manual and the warning labels affixed to the machine provide notification of specific potential hazards.

The following instructions are only a guideline and should be considered a supplement to your plant's comprehensive safety program. Your business' policy supersedes these guidelines if at any time the two contradict each other. Please read and understand the manual including all of the danger, warnings, and caution statements. If after reading the manual you have questions, contact your supervisor or your Pregis service technician to get answers before working with the machine.

1. Only authorized personnel may use the equipment.
2. Only trained authorized persons will carry out any adjustments, repairs, maintenance or cleaning with the equipment isolated from power supply and no longer in motion.
3. Never deface or remove factory installed warning decals. If a decal ever becomes lost, damaged, or illegible, report this condition to a supervisor and obtain a replacement decal from Pregis.
4. Keep the work area clean and uncluttered. Walking surfaces should always be free of packing material and debris to prevent a slipping or tripping hazard.
5. Ensure that all covers, guards and other safety devices are in place. NEVER defeat a safety device for any reason.
6. Follow the recommended procedures in this manual.
7. Never leave the equipment unattended while operating. Shut the machine off if you must leave the work area.
8. Keep body parts and clothing away from moving components. NEVER reach into the machine for any reason while it is in motion.
9. Understand proper material path and safe loading procedures.
10. Understand which adjustments are operator adjustments; contact maintenance person for all other adjustments.
11. **DO NOT** operate equipment if you are under the influence of alcohol, drugs or medications that can make you less alert or affect your judgment.

Understanding the Controls

The Power Switch for the Quantum Series is used to turn the electrical power “ON” or “OFF” and is located on the right side of the head assembly, next to the power inlet.



When operating the Quantum Series, the most commonly used component is the foot pedal (may need to extend head to insert foot pedal using the telescoping function). Its functions include:

- Starting and stopping the machine (i.e. dispensing material)
- Reset for Powered Tear Assist (PTA), Feed to Length (FTL), Auto-Feed to Length (A-FTL) functions
- Override for all modes of operation

Head Assembly Controls

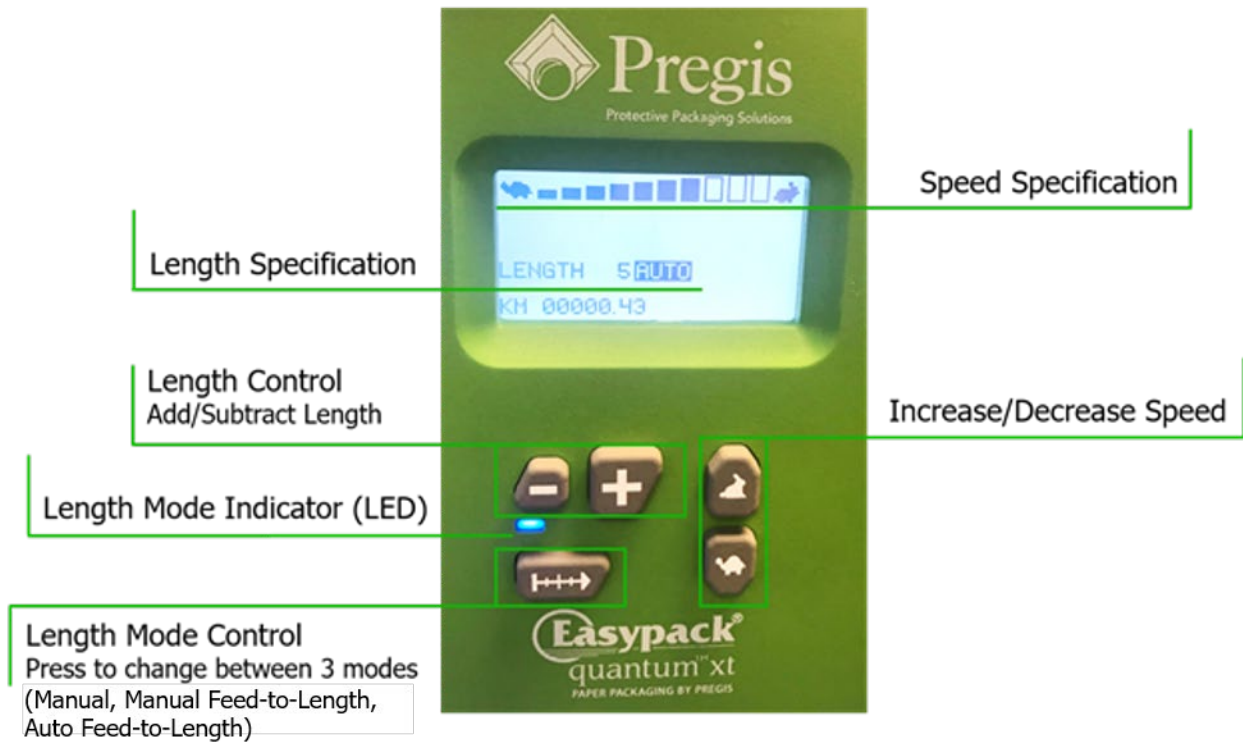
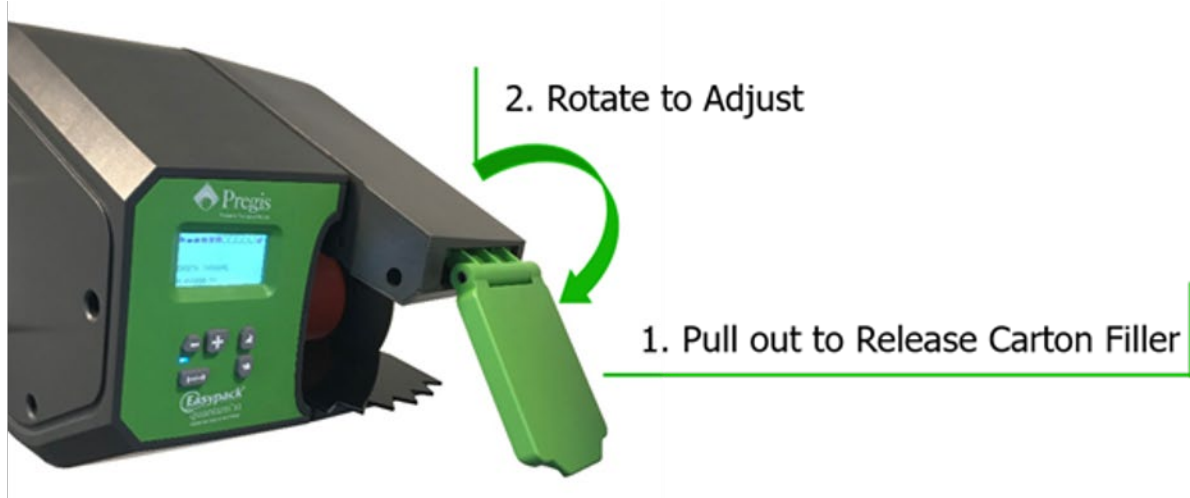

Operation

1. DO NOT attempt to defeat any safety feature.
2. DO NOT place any part of your person or foreign object into the drive.
3. Keep clear of all pinch points while machine is running.
4. DO NOT operate the machine if any part of your body becomes fatigued.
5. DO NOT operate the machine if you are under the influence of alcohol, drugs or medications that can make you less alert or affect your judgment.

Operating Modes:

- Manual Mode
- Manual Feed-to-Length (FTL) Mode
- Auto Feed-to-Length (A-FTL) Mode

It is important to note, all modes share certain features, which are detailed below:

Manual Mode:

The manual setting allows the operator to dispense material using the foot pedal only. In this mode, machine speed can be adjusted to user preference as needed.

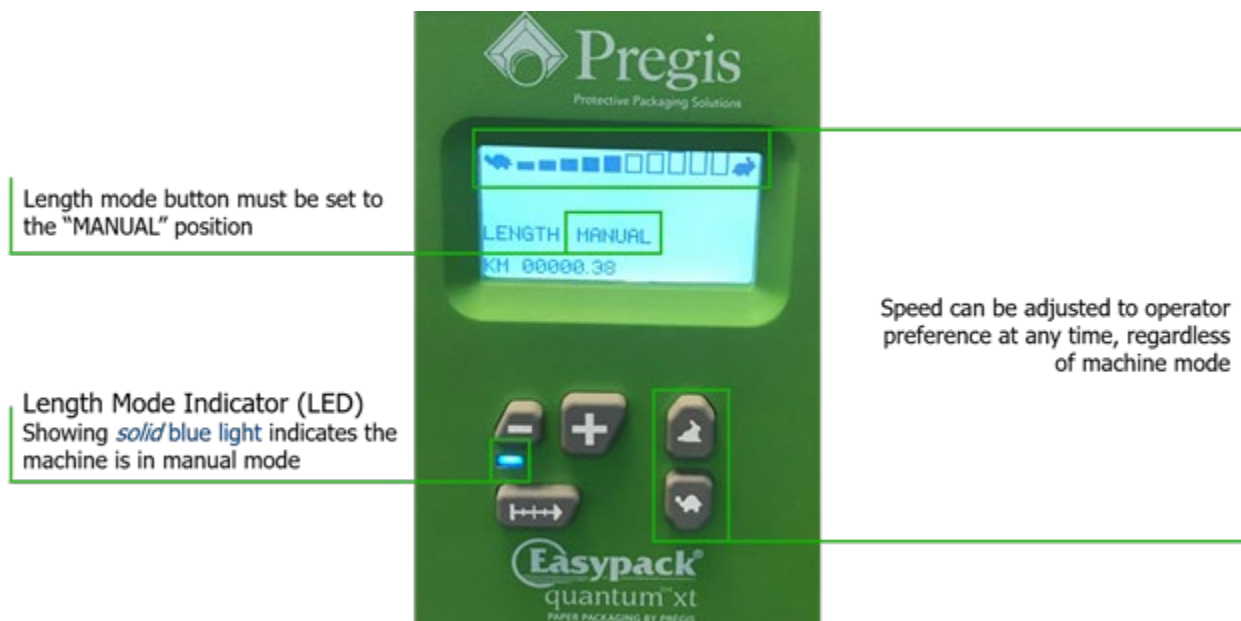

Manual Feed-to-Length (FTL) Mode

The manual feed-to-length (FTL) setting allows the operator to dispense a preset length of material by activating the foot pedal briefly (i.e. “tapping” the foot pedal). Once the foot pedal is “tapped” (activated briefly) the machine will dispense a preset length of material. The operator must repeat the process to receive additional, preset lengths of material. In this mode, the foot pedal also acts as an override. To receive a length of material greater than the preset length, press and hold the foot pedal until the desired length is received. The preset length can be adjusted (using the add/subtract buttons on head assembly) as needed.

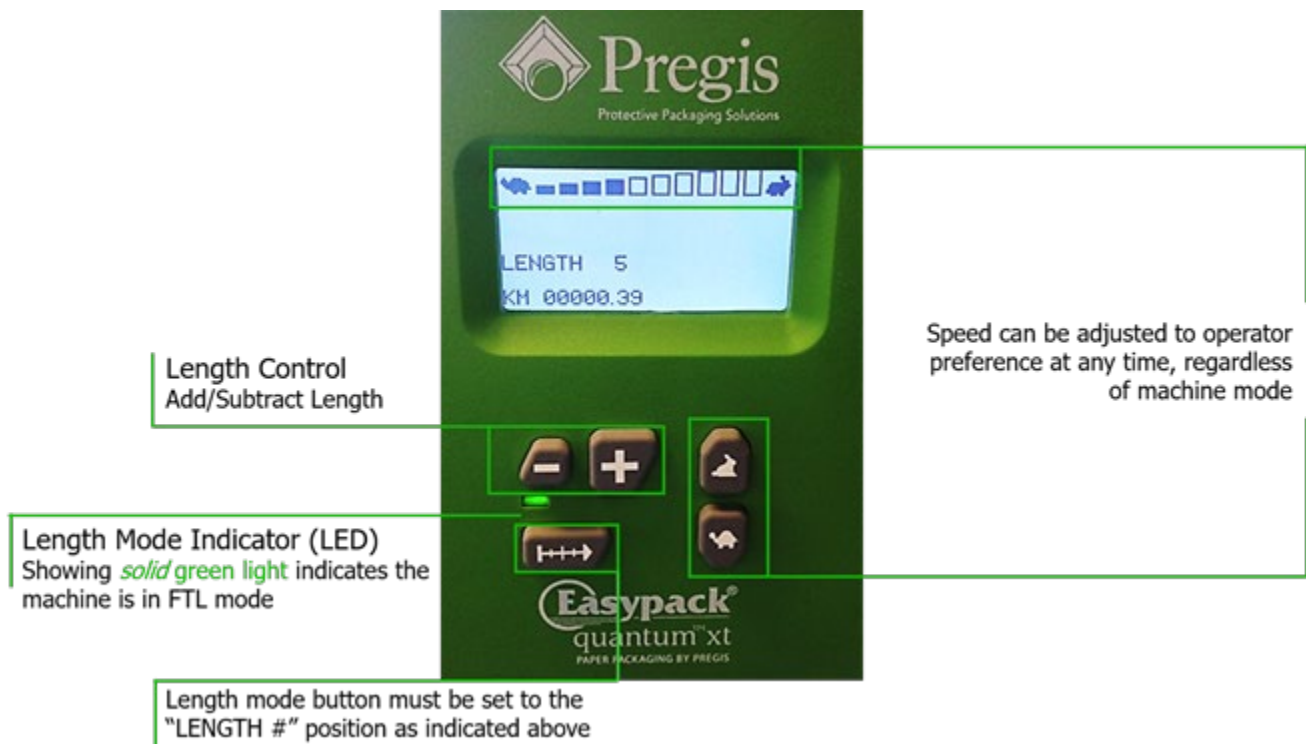

Preset Lengths

There are 10 preset length settings. As you press the length control (add/subtract) button, the machine will dispense a length of material equivalent to one 360 degree revolution of the drive roller (approximately 9 inches of material). The length setting “1” defaults to 2 revolutions. Each increase in length adds one additional revolution (up to 11 revolutions).

Auto Feed-to-Length (A-FTL) Mode

The auto feed-to-length (A-FTL) setting allows the operator to dispense a preset length of material. Once the powered tear assist feature is activated (see Powered Tear Assist section), the machine will automatically dispense another preset length of material (same as previous). This process will continue as long as the feature is active. The foot pedal also acts as an override in this mode. To receive a length of material greater than the preset length, press and hold the foot pedal until the desired length is received. The preset length can be adjusted (using the add/subtract buttons on head assembly) as needed.



Preset Lengths:

There are 10 preset length settings. As you press the length control (add/subtract) button (**As mentioned above, the A-FTL feature defaults to the shortest preset length (2 revolutions)**), the machine will dispense a length of material equivalent to one 360 degree revolution of the drive roller (approximately 9 inches of material). The length setting "1" defaults to 2 revolutions. Each increase in length adds one additional revolution (up to 11 revolutions).

Powered Tear Assist (PTA)

The powered tear assist (PTA) feature was designed to reduce the amount of force it takes to tear the void fill material. Once material has been dispensed, the powered tear assist feature becomes active. To use this feature, simply pull the void fill material against the tear assist in a downward motion as shown below. The tear assist will pivot downward (slightly), which activates an internal switch. Once the switch is activated, the machine will rotate the motor in reverse, pulling the material against the tear assist, which tears the material. Note: This feature remains active for one cycle. To repeat the function, simply press the foot pedal.



Quantum XT Loading (Pull from Center Paper)

1. Place a roll of Quantum paper into the roll cradle



2. Pull out the overlapped material (roll core) and either unroll or tear off the material (save for later use).



3. Lift the upper-roller assembly.



4. Insert the paper over the breaker bar (if equipped), through the inlet, and below the upper-roller assembly. Position the material forward of the drive rollers and above the tear assist.



5. With paper through the roller and over the tear-assist, lower the upper-roller assembly.



Quantum XTW Magazine Loading (Fanfold Paper)

1. Lock the front two casters and open the doors by lifting and then pulling the knobs.



2. Load the first bundle of paper with the splice arrow facing you. Note:

- The bundle should be touching the back wall of the magazine
- Flatten the bottom corners as necessary



3. Cut the sleeves inwards with a strap cutter, pull the sleeves straight out holding the bundle with your other hand.



4. To connect paper bundles for continuous dispensing, see directions printed on labels of the paper bundle.

See label on paper bundle for details

5. Repeat that process up to 5 bundles high, then lift, rotate and close the doors, locking them in place.



6. Position the magazine squarely behind the machine and lock all 4 casters.



Quantum XTW Magazine Loading (Fanfold Paper) Cont'd

7. *Click* the upper roller assembly into the open position.



8. Crumple the top 2-3 feet of the paper bundle, tightly twist the end. Next feed it through the safety shrouding & up to the orange roller.



9. Pull the paper out and over the tear plate, then close the upper roller assembly.

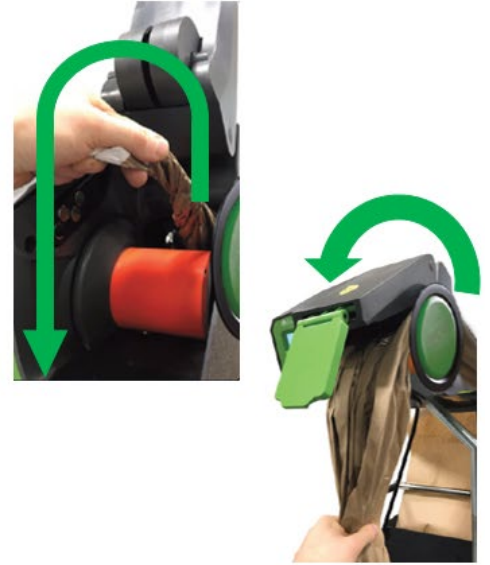

Maintenance

The Quantum Series is designed to require little to no maintenance. The following recommended maintenance items will help keep the Quantum Series operating correctly and minimize any down time on your packaging line. If there are any questions regarding the maintenance of the Quantum Series, please contact your local Pregis Service Technician for assistance.



Electrical shock or unexpected machine movement can cause injury. Unplug the machine before performing maintenance tasks.

Disconnect the power cord before performing ANY maintenance to the machine other than inspections.

Monthly Maintenance:

1. Machine should be cleaned periodically to maintain a clean work environment.
2. Verify all components are working properly. If there are any issues, please contact your Pregis Service Technician

Trouble Shooting



Electrical shock or unexpected machine movement can cause injury. Unplug the machine before performing troubleshooting tasks.

Problem: Machine will not power on.

Cause: Machine not set-up properly.

Solution:

1. Verify LCD display is off.
2. Check power cord. Make sure it is plugged in correctly to a good, known power source.
3. Verify power switch is in the “On” (I) position.

Problem: Machine is powered on but will not run.

Cause: Head assembly cables/foot pedal cable not connected properly.

Solution: Verify cable connections.

Problem: Upper roller assembly keeps “popping up” while running material.

Cause: Magnet block assembly not properly adjusted.

Solution: Contact Pregis Service 1 866-904-6979

Quantum XT Machine Specifications

Machine Weight: 35 lbs

Machine and Floor Stand: 75 lbs

Power Requirements: 3 Amps

Side Profile

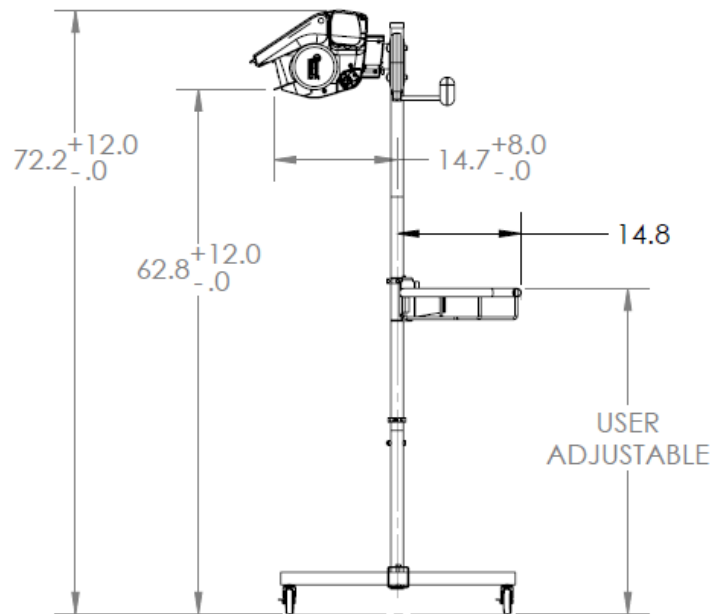

Overhead

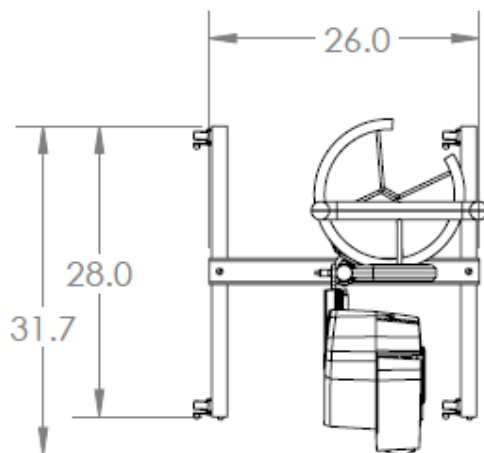

Quantum XTW Machine Specifications

- Machine Weight: 35 lbs
- Machine and Floor Stand: 75 lbs
- Magazine Weight (Un-loaded): 115 lbs
- Power Requirements: 3 Amps

Front

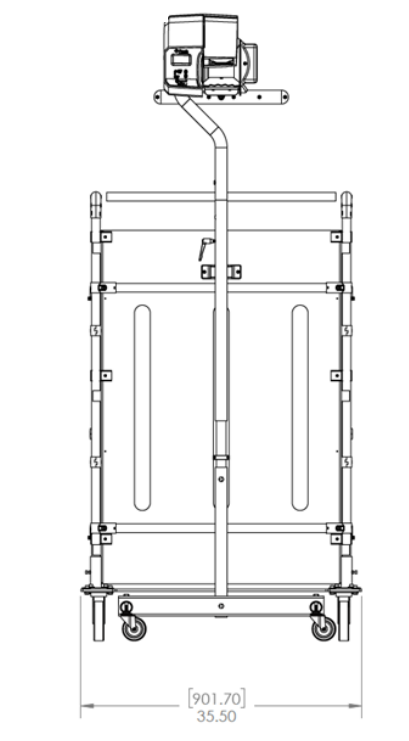

Side Profile

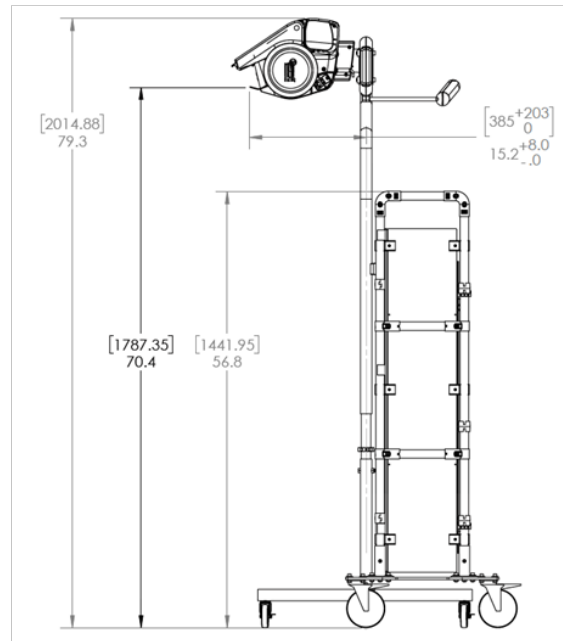

Overhead

